





# FreeLifeSTYLE

technology to enhance your life

We project and create innovative systems for going up and down staircases. By connecting floors and slight height differences, in order to ease one's daily life as well as to increase environmental value.

We present you two new product lines, ComfortLine and MovingLine, created for comfort and ease of movement which allows one to use space in an autonomous way.



lightness day after day



Movement can become a difficulty for anyone.

With Our Freestyle products, it enhances the spirits of a mother with a buggy, who lives in a building of several floors where one may either temporarily, permanently or due simply over a period of time have natural motorial difficulty, or may be in need of such a product. We help everyone without age limit to access every type of ambience, environment and space in an independent autonomous way.

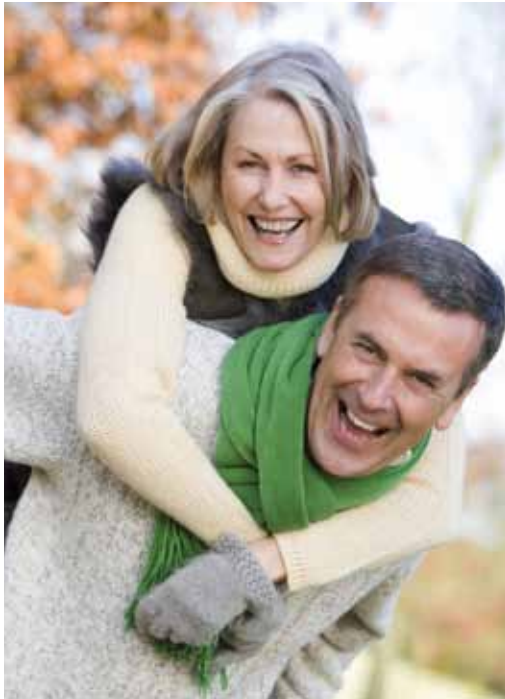



## experience serving people

To make your life easier is our duty.

We are close to your needs by developing viability in service even after installation.

The attention and care we take in the creation of each of our products is the same attention and care we dedicate to its whole life cycle.



Alongside the customer, we always follow and give our total experience in the field to your every need from the beginning to the end.

We draft with you the ideal solution, by overlooking the site in order to prepare a clear personalized quota, keeping you informed at all times and giving all the necessary support for a subsidized purchase either local or governmental. We carefully take all the necessary and proper measurements accurately, paying attention to the slightest details. All our blueprints are presented meticulously and we give a helping hand to the customer's draftperson for possible structure works.

Our qualified personnel is periodically updated in the latest installation techniques. In order to guarantee that the product be fully functional. Which is carried out by our Authorized Technical Centres and certified by Declaration of Conformity.

We look after our customers during and after the purchase of our products through our customer service centre guaranteeing our customers our total availability. All our items are EC certified and are covered by insurance for civil responsibility on products. We furthermore offer additional services as the opportunity of a 5 year warranty extension\*, programmed maintenance service with prioritized assistance, revision and refurbishing of the existing installations.

*\*Warranty Exthentions Pack available by Authorised Centres*

More comfortable and totally independent products for your daily life.



comfortline

p8 **dhome**lift  
Elevator in enclosed liftway

p10 **maggy**lift  
Chair Stairlift

p12 **margie**lift  
Chair Stairlift

p14 **obe**lift  
Standing Stairlift





# MOVINGLINE

Products to ease mobility of people and accessibility to spaces.



qubeLift p16  
Platform Lift

hideLift p18  
Platform Lift with sliding floor

ARCOlift p20  
Platform Stairlift

BancoLift p22  
Micro Lift



A fully functional product that does not neglect comfort and appearance

The elevator that is highly adaptable to whatever building, customizable into any installation, dimension and finishing. Dhomelift warrants the comfort of a conventional elevator, catlike silence and smooth approach movement to the floors level.

Thanks to a control dedicated key system, Dhomelift can serve contemporaneously several homes, maintaining the safeguard and privacy of them. All thanks to an easy comfortable push button control panel within the cabin.

# dhomeLift

Elevator in enclosed liftway



kg 400

maximum load



### characteristics



- Door features to floor levels with big window.
- Internal Light timer
- Cabin supplied with a stainless steel tubular handrail
- Installation carried out with minimum mural works.
- Push button control panels within the cabin and at the floor levels in maxi highlighted buttons
- Cabin available complete with photoelectric sensors and hold to run push button control panel type or with cabin folding doors and automatic manoeuvres

## Comfortable and versatile even with the scenic view cabin



### Installation typologies

Installation in closed shaft masonry work perfectly installable in any modern or vintage building

Metallic structure installation finishing available in colour or stainless steel.

Cabin walls with round lines can be personalized, either with glass or mirrors.



## The possibility to move in complete autonomy in front of awkward situations

Going up or down the stairs internally or externally, with Maggylift, the simple and essential seat fitted with a cosy and a compact closable seat in its resting position. Thanks to the swivel chair, Maggylift has an optimal swivel assistance for disembarking at floor levels. Reliable also in emergency situations, its functionality is guaranteed even when there is a power failure, Maggylift is perfectly adaptable in any domestic environment.

# Maggylift

Chair Stairlift



## characteristics



- Adjustable back seat rest for a better position of the person
- Rapid safety release standard feature
- Simple and intuitive push button control panels, placed on the armrests in a comfortable and visual position
- Seat covers are made in washable material, without having to remove them
- Footrest coated in anti-slip material
- Safety devices placed on the machine body and footrest platform
- Dry smooth rounded off guide rails



### various seat colours:

Cherry, Cinnamon, and Chocolate



kg 130

maximum load

Easy and Light, which allows you to move freely at home



### COMPACT

Closable in the rest position to reduce the encumbrance and allow free passage after usage.



Synchronized closure between the seat and footrest without the need to bend over.



### SWIVEL SEAT

Turning seat towards the top floor level to ease the descent and the for safety of the user, without a downward rotation.





## Soundness linked to an easy usage

Maximum comfort with Margielift, seat of extra large dimensions has a particular cosy and functional seating. Margielift, is made from a complex reinforced robust arm and footrest made in a particular way where one can stand up or sit down on it with ease. The simple, intuitive, and easy to use push button control panel is placed in a visual position on the armrest. The seat can be set up in any stairs type, straight, curved, internal turn, external turn, either outside or inside environment.

# Margie<sup>lift</sup>

Chair Stairlift



## characteristics



- Wide and comfortable seat, stuffed armrests and back rest, available in 3 different colours
- Seat belt with rapid release as standard feature
- Simple and intuitive push button control panels, placed on the armrests in a comfortable and visual position
- Seat covers are made in washable material, without having to remove it
- Footrest coated in anti-slip material
- Safety devices placed on the machine body and footrest platform
- Dry smooth rounded off guide rails

### various seat colours:

Cherry, Cinnamon, and Chocolate.



**maximum load**

Practical and comfortable, it is easily installed even in limited spaces



### COMPACT

Seat, armrest and footrest platform closable in rest position to reduce the clutter to a minimal on the staircase.



### SWIVEL SEAT

Turning seat towards the top floor level to ease the descent.

Thanks to the swivel seat and minimum height from the ground, it is accessible also to wheelchair users.



Day to day  
comfort

COMING SOON

obe<sup>lift</sup>

Standing Stairlift

Obelift transforms one need into comfort, the stairlift which relieves the difficulty of going up and down the stairs even with small loads. Equipped with an adequate platform dimension where it can be used by a standing user and equipped push button control panel on foldable armrest. Easy installation and usage. Obelift is suitable for any type of staircase and environment.



## characteristics

- Foldable seat, for transporting a seated person
- Push button control panels placed on armrests
- Object compartment standard feature
- Safety bumper sensors on the machine body and footrest platform
- Dry smooth rounded off guide rails

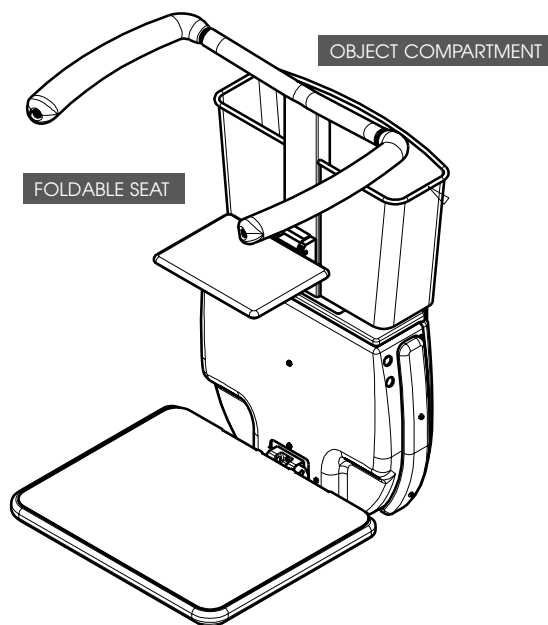

kg 130

maximum load

## Weight relief, either standing or sitting

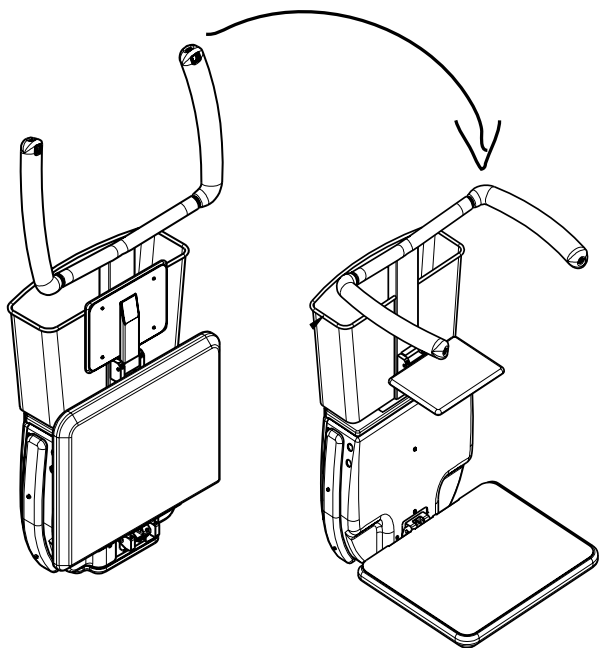

### SIMPLE AND PRACTICAL

Platform adequately proportioned for the transportation of standing users even with small loads. Armrest to be used by the user or to carry shopping objects.

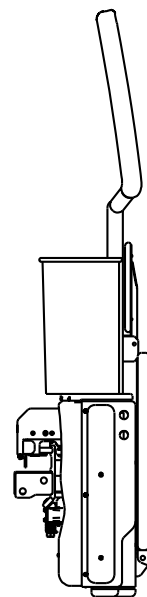

### COMPACT

Closable in the rest position to reduce the encumbrance and allow free passage after usage.



## Beauty weds comfort

Qubelift, the optimal solution to reach balconies or landings. To be installed in harmony with the present buildings in compliance with the architectural balances: without invasive frames, clean and linear finishing, rounded off mounts, handrail along the glass length and disappearing bellows which characterises the style.

Easy installation, minimum mural works needed and complete with control and command devices.

# qubeLift

Platform Lift in open liftway



kg 300

maximum load

## characteristics



- Panel control on board with easy legible Up / Down indicators
- Stainless steel call push button panels placed at floor levels
- Glass gates and doors, available in diverse transparent tonalities
- Platform coated in anti-slip rubber or from anti-slip alluminum
- Disappearing bellows and sensitive safety edge around the platform perimeter
- Anti-black out safety device and emergency back up battery for emergency descent in case of power failure



## Perfectly integrated even in prestigious environments



### TRANSPARENCY AND DESIGN

Fitted with crystal glass for a uniform finishing for landings and balconies.



### HI-TECH FINISHING

Gate and Top floor door fitted with aluminium mounts.



Handrail along the whole side length for an easy grip.



## Useful and disappearing

To overcome the few steps with elegance thanks to Hidelift, the lifting platform with disappearing edge in the resting position: no clutter on the staircase after usage. Maximum safety with minimum impact: safety sensor devices on the front side and under the platform, floor can be coated for a better environmental look.

# HideLift

Platform Lift with horizontal sliding floor



## characteristics



- Disappearing edge in the resting position, with a restraint function during lifting platform movement
- Push button control panels placed on floor levels and on board
- Safety sensor devices placed in front and under the edges of the lifting platform
- Platform coated in anti-slip rubber or anti-slip aluminium, or floor surface coating available



No clutter and highly useful

kg 300

maximum load

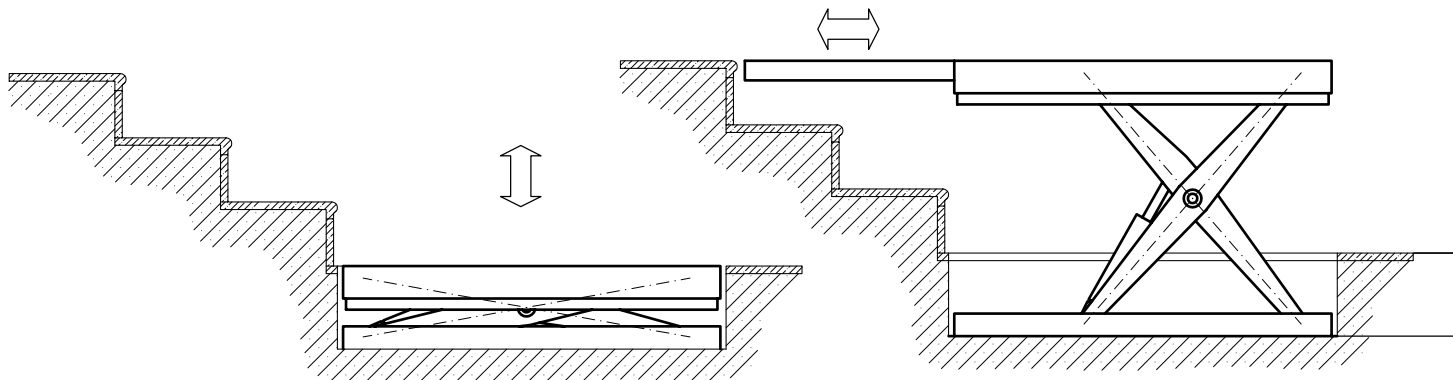

## HARMONY AND FUNCTIONALITY

The lifting platform in its resting position folds away into the ground maximizing the surrounding space without any aesthetic alteration.

## EASY AND SAFE ACCESS

Platform lift with horizontal sliding floor with the arrival to the upper landing.



## The best way to overcome barriers

Arcolift helps overcome obstacles where staircases or steps block the access for wheelchair users, the stairlift perfectly in line with the demand of simplicity and safe usage. The commands are positioned in a logical and practical way on the machine body for embarking and disembarking at floor levels. Thanks to great flexibility and attentive aesthetics, Arcolift is useable in any type of staircase, either straight or curved and its functioning is safe, reliable even in external installations.

# ARCOLIFT

Platform Stairlift



kg 230

maximum load

## characteristics



- Powered platform equipped with automatic ramps, serving as connecting slide ramps for floor levels
- Multi-Access Platform: access available on three sides contemporaneously
- Powered double armrest protection with anti-vandalism
- Treading platform surface coated with anti-slip.
- Bumper safety sensors placed on the machine body and under the platform
- Dry smooth rounded off guide rails
- Remote control push button control panel for assistant, folding seat for sitting person, upon request



## Robust, safe and reliable



### COMPACT

Closable in the rest position to reduce the encumbrance and allow free passage after usage.



### EASY AND SAFE

Simple and safe usage thanks to the powered armrest and platform that can be operated from the floor level commands.





## Life made easy in its practical aspects

Bancolift helps overcome slight height differences and allows access to ATM's and vendor machines. The micro elevator is ideal where accessibility is a problem due to its surrounding circumstances is strongly influenced. No clutter in its resting position. Bancolift in its dolly version, is versatile and can be easily used in various situations. The movements are completely motorized and activated by external wireless remote control push button panel or fixed push button control panel on the floor level or on board. Its functioning is autonomous and structural works minimally invasive, Bancolift is also equipped with rechargeable batteries and anchorage to walls or floors.

# BancoLift

Micro Lift



## characteristics



- Multi-Access Platform: with angled edge, reversible for easy access to the platform and for a better landing support to floor levels
- Powered opening and closing movements of the platform
- Anti-shock / Anti-crushing device under the platform
- Installation without mural works
- Autonomous functioning with rechargeable batteries
- Fixed version: Anchorage to floor or either floor and walls
- Mobile version: manual trolley for movement, with a telescopic arms, removable steering wheel, wheels and ramps



To overcome slight height differences, easy to install even in limited spaces



### COMPACT

Cluttering drastically reduced with platform closed in resting position: without commitment and encumbrance it guarantees safety protection to lifting means and commands.

### EASY AND SAFE

Can be operated by infrared remote control or push button control panel.

## contact

### **Manufacturing and Production**

SITES SRL  
Via Cavalieri di Vittorio Veneto  
23870 Cernusco Lombardone - LC (Italy)  
Tel +39 039 999 18.1  
Fax +39 039 999 18.55  
info@sites.it

### **Sales Office FreeLifeStyle**

SITES SERVICE SRL  
Via Bergamina 2/A, angolo Via Figino  
20016 Pero - MI (Italy)  
Tel +39 02 33915711  
Fax +39 02 33915755  
info.service@sites.it

SITES SER S.L.  
Ctra. Barcelona, 181  
08201 Sabadell, Barcelona (Spain)  
Tel. +34 93 0014951  
Fax +34 93 7272536  
info.ser@sitesgroup.es

Data, characteristics and features are approximate and non binding, are subject to change without notice.

